

www.packmangroup.com



Knowledge
Based

Since 1975



PACKMAN
Industrial Group

 Firebox Hot Water Boiler
powered by PACKMAN industrial group



Firebox Hot Water Boiler



Product Description

The Packaged Fire Tube Boiler has proven to be highly efficient and cost effective in generating energy for processes and heating applications. Efficient Firebox threepass designs are available from 100KW to 1200KW range. Our firebox boilers are equipped with a forced flat flame retention burner which results in high efficiency over i.e 85. This boiler-burner combination gives reliable operation with minimum maintenance.

Standard Features

All Firebox units contain operating control, systems relief valves, burner and fuel train. The installation is simple and only service connections need to be placed. Compatible with natural gas, oil or dual burners. High density 2” mineral wool insulation assures lower radiant heat loss.

Efficiency

Conventional atmospheric burners operate with high excess air up to 300% causing the flame temperature to be decreased. It is obvious that excess air has substantial effect on flame temperature and consequently on the rate of heat transfer and efficiency. Forced draft burners which are used in our boilers operate at lower excess air, about 10-30 percent.

This results in an acceptable efficiency about 84-85% with less operation cost. The initial cost of a boiler is the smallest portion of your boiler investment. Fuel costs and maintenance costs represent the largest portion of your boiler equipment investment. Some basic design differences can reveal huge variations in expected efficiency & performance levels. Evaluating these design differences can provide insight into what efficiency value and resulting operating costs you can expect.





100-400 KW

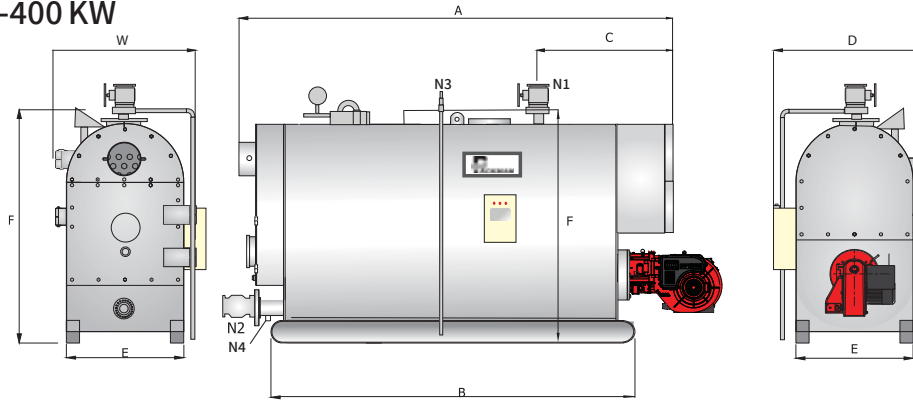

Model	Unit	PHWB-FB-100	PHWB-FB-150	PHWB-FB-200	PHWB-FB-250	PHWB-FB-325	PHWB-FB-400
Technical Data							
Thermal Capacity	kw	100	150	200	250	325	400
Thermal Capacity	kcal/hr	86,000	129,000	172,000	215,000	280,000	344,000
Working Pressure	bar	Up to 16 bar					
Heating Surface	m ²	3	5	6	8	10	13
Pressure Drop in Combustion Chamber	mbar	2.20	2.20	2.50	2.50	2.20	2.50
Design Standard	-	BS/EN 12953					
Max Gas Consumption @Sea Level	m ³ /hr	10	15	20	25	32.5	40
Max Fuel Oil Consumption @Sea Level	liter/hr	8.3	12.5	16.7	20.8	27	33.3
Max Heavy Fuel Oil Consumption @Sea Level	liter/hr	7.1	10.7	14.3	17.8	23.2	28.6
Connectoins Size							
Water Outlet (N ₁)	in	2	2	2	3	3	3
Water Inlet (N ₂)	in	2	2	2	3	3	3
Safety Valve (N ₃)	in	1	1	1	1	1	1
Drain Valve (N ₄)	in	1	1	1	1	1	1
Stack I.D. (N ₅)	in	6	6	6	8	8	8
Expansion Inlet	in	1	1	1	1	1	1
Boiler Dimensions							
Length (A)	mm	1,490	1,640	1,840	1,910	2,110	2,310
Skid (B)	mm	1,220	1,360	1,570	1,550	1,750	1,950
Overall Width (D)	mm	960	960	960	1,100	1,100	1,100
Width (W)	mm	790	790	790	920	920	920
Height (F)	mm	1,320	1,320	1,320	1,590	1,590	1,590
Min Front Clearance	mm	1,200	1,320	1,520	1,570	1,690	1,970
Min Rear Clearance	mm	700	700	700	800	800	800
Min Side Clearance	mm	500	500	500	500	500	500
Min Boiler Room Length	mm	3,390	3,660	4,060	4,280	4,600	5,080
Weight							
Shipping Weight @ 10 bar Working Pressure	kg	900	930	1,000	1,400	1,500	1,650

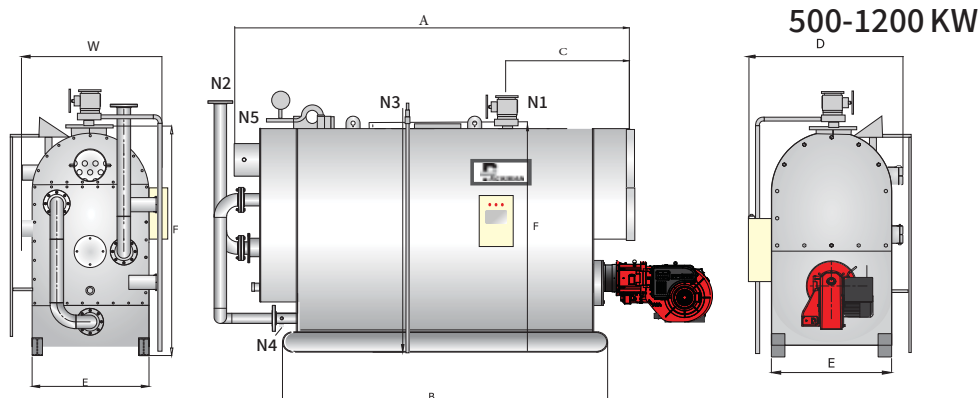

Model	Unit	PHWB-FB-500	PHWB-FB-600	PHWB-FB-700	PHWB-FB-800	PHWB-FB-900	PHWB-FB-1000	PHWB-FB-1200
Technical Data								
Thermal Capacity	kw	500	600	700	800	900	1,000	1,200
Thermal Capacity	kcal/hr	430,000	516,000	602,000	688,000	774,000	860,000	1,032,000
Working Pressure	bar	Up to 16 bar						
Heating Surface	m ²	16	19	22	25	27	31	38
Pressure Drop in Combustion Chamber	mbar	3.50	3.00	2.50	3.80	3.8	3.92	5.88
Design Standard	-	BS/EN 12953						
Max Gas Consumption @Sea Level	m ³ /hr	50	60	70	80	90	100	120
Max Fuel Oil Consumption @Sea Level	liter/hr	41.7	50	58.3	66.7	75	83.3	100
Max Heavy Fuel Oil Consumption @Sea Level	liter/hr	35.7	42.8	50	57.1	64.3	71.4	85.7
Connectoins Size								
Water Outlet (N ₁)	in	4	4	4	4	4	4	4
Water Inlet (N ₂)	in	4	4	4	4	4	4	4
Safety Valve (N ₃)	in	1 1/2	1 1/2	1 1/2	1 1/2	1 1/2	1 1/2	2
Drain Valve (N ₄)	in	1	1	1	1	1 1/2	1 1/2	1 1/2
Stack I.D. (N ₅)	in	10	10	10	10	10	10	10
Expansion Inlet	in	1 1/2	1 1/2	1 1/2	1 1/2	1 1/2	1 1/2	2
Boiler Dimensions								
Length (A)	mm	2,450	2,590	2,750	2,900	3,070	3,240	3,450
Skid (B)	mm	2,050	2,190	2,350	2,500	2,650	2,800	3,000
Overall Width (D)	mm	1,260	1,260	1,260	1,260	1,260	1,340	1,340
Width (W)	mm	1,080	1,080	1,080	1,080	1,080	1,160	1,160
Height (F)	mm	1,920	1,920	1,920	1,920	1,920	2,050	2,050
Min Front Clearance	mm	2,130	2,300	2,450	2,600	2,800	3,000	3,200
Min Rear Clearance	mm	1,000	1,000	1,000	1,000	1,000	1,200	1,200
Min Side Clearance	mm	700	700	700	700	700	1,000	1,000
Min Boiler Room Length	mm	5,580	5,890	6,200	6,500	6,870	7,440	7,850
Weight								
Shipping Weight @ 10 bar Working Pressure	kg	2,500	2,700	3,000	3,100	3,150	3,900	4,000

PACKMAN GROUP

History

The Packman Company was founded in February 1975, and was soon afterwards registered in companies Registration Office. In early years the Packman construction and service branch focused on building installations. Different mega power plants were built by cooperating with Brown Boveri and Asseck companies in 1976.

The company started its official activities in construction of High-Pressure Vessels such as Hot-Water Boilers, Steam Boilers , Storage Tanks, Softeners and Heat Exchangers from 1984.

Packman Company is one of the first companies which supplied the high quality and standard hot water boilers to the customers.

Packman has exported its products to countries such as Uzbekistan, United Arab Emirates and other countries in the Middle East. It is one of the largest producers of hot-water and steam boilers in the Middle East.

Now we are proud to announce that the Packman industrial group has five major sub-brands that have product titles in all field of HVAC equipment and engineering services, and we do not know this success except with the help and support of our customers.

1. Construction Services Industry Association
2. Industry Association
3. Construction Companies' Syndicate
4. Technical Department Association
5. Mechanical Engineering Association
6. Engineering Standard Association

Departements:

Sales Deps:

- ∩ Power Plant & Petrochemical
- ∩ Industrial
- ∩ Hospitally Service
- ∩ Commercial & Residential
- ∩ Sport Complex & Pool

Technical Deps:

- ≡ Manufacturing R&D
- ≡ Innovation Center
- ≡ EPC Execute Unit
- ≡ Product Develop Unit
- ≡ Sales Engineering Dep.

Others:

- ≈ After Sales Service
- ≈ Project Control
- ≈ Financial Office
- ≈ Commercial Office
- ≈ Marketing Department



PACKMAN GROUP Brands



PACKMAN
Industrial Group

Designer & manufacturer of Condensing, Hot Water, Steam, Hot Oil & Waste Heat Boilers, Heat Exchangers, Autoclave Pressure & Storage Vessels & etc



GREENMAN
Green mindset, green future

Engineering & Designing Commercial Greenhouse Plant, CO2 Dosing System, Flue gas Condenser & Special HVAC Systems, Sustainable Agriculture & etc



ROMAN
Water solution

Designer & manufacturer Reverse Osmosis Plant & Package, Water Treatment, Softener & Filters and Chemical Dosing Systems & etc



RAADMAN
a look to the future

Designer & manufacturer of Industrial Mono & Dual Block Gas, LPG, Light & Heavy Oil Burners, Premixed & Postmixed Burners, Watertube burners, Process burners, Special application burners & Combustion Solutions & etc



CHILLMAN
Coolest hvac around

Designer & manufacturer of Air & Water Cooled Chillers, Air Handling Units, Fancoil, HVAC Equipment, Cold Storage Room & etc



1. Isfahan Factory



2. Vilashahr Factory



3. Parand Factory



4. Parand (2) Factory



5. Bonyad Factory

SOME OF Certificates are



Knowledge Based



PACKMAN



GREENMAN



ROMAN



RAADMAN



CHILLMAN

+9821 42 362

www.packmangroup.com

No 14, 10th Alley, Beihaghi St., Argentina Sq., Tehran-Iran